



Gearless lift driving systems with motors: SVM 250-04
SVM 250-06
SVM 250-08
SVM 250-10
SVM 250-13
SVM 250-15





LOHER GmbH
POB 1164 • D-94095 Ruhstorf
Hans-Loher-Sr. 32 • D-94099 Ruhstorf
Germany
Telephone + 49 8531 39-554
Telefax + 49 8531 39-569
<http://www.loher.de>
e-mail: lift@loher.de

Important notes in advance

Installation and commissioning of the components described in this operating instruction to be carried out by trained personnel of a professional lift company only.

The operating instruction includes safety instructions in the form of pictographs pointing to the hazards. The pictographs indicate the kind of hazard.

Table: Meaning of the pictographs

Used pictographs	Signal words	Meaning
<p>Warning against electrical voltage</p> 	Danger	<p>Warning against an immediate danger.</p> <p>Consequences if disregarded: Death or very serious injuries</p>
<p>Warning against a general danger</p> 	Warning Caution	<ol style="list-style-type: none"> 1. Warning against a possible, highly dangerous situation. Possible consequences if disregarded: Death or very serious injuries 2. Warning against a possibly dangerous situation. Possible consequences if disregarded: Minor injuries
<p>Warning against material damages</p> 	Stop!	<p>Warning against possible material damages.</p> <p>Possible consequences if disregarded: Damage of the drive system or its environment.</p>
<p>Information</p> 	Tip!	<p>Marks a useful tip.</p> <p>Observing this facilitates the handling of the drive system or the respective device .</p>

Contents

Introduction and general notes

Covering page (pictures)	5
About these operating instructions	5
Scope of supply.....	5-6
Documentation	6

Type plates and type code

Type plate 1.....	7
Type plate 2	8
Type code 2	8
Type plate 3	9
Type code 3	9

Legal provisions

General notes.....	10
Intended use	10
Warranty	10
Damages in transport	10

Safety instructions

General notes.....	11
Persons responsible for the safety	12
Operating conditions for the DYNASYS® S drives	12
Transport.....	13

Description of the product

Frequency inverter	14
Motor.....	14-16
Speed and position encoder	16
Traction sheave	16-17
Brake.....	17

Installation

Installation and operation of the driving unit	17
--	----

Electrical connections

General notes	19
Terminal box	20-21
Speed and position encoder	21

Contents

Technical data

Motor.....	22-24
Fatigue strength of traction sheave shaft	24-25
Forced ventilation	26
Speed and position encoder.....	26
Brake	26-27
Traction sheave	27

Maintenance and repair

General notes	28
Disassembly of the speed and position encoder	28
Disassembly of the traction sheave	29
Maintenance	29
Maintenance intervals	29-30
Lifetime of motor bearing.....	30
Lubrication.....	30
Spare parts list.....	31
Storage.....	31

Important actions prior to commissioning

Observe and check	32
-------------------------	----

Check list for adjustment of inverter DYNAVERT® L05

List of parameters	33-34
--------------------------	-------

Dimensional drawings

SVM 250-04 and 06, brake w/o manual lifting.....	35
SVM 250-04 and 06, brake with manual lifting	36
SVM 250-08 and 10, brake w/o manual lifting	37
SVM 250-13 and 15, brake with manual lifting	38



The operating instruction for the brake is a separate document and is not included in this manual. The respective actual version of the brake manufacturer is enclosed to each supply.

The operating instruction for the brake can be downloaded directly from the homepage of the manufacturer Mayr Antriebstechnik under <http://www.mayr.de>.

Introduction and general notes

Covering page

System DYNASYS® S

Upper picture, left: Frequency inverter DYNAVERT® Series L05

Upper picture, right: Motor type SVM 250-04, brake ROBA-stop® - Silenzio® without manual brake lifting device

Lower picture, right: Motor type SVM 250-15, brake ROBA-stop® - Silenzio® with manual brake lifting device

About these operating instructions

Subject of this operating instruction is a driving system for lifts. The system is composed of the components motor, brake, speed and position encoder, traction sheave and frequency inverter.

Repair of the individual components of the system by the user or the installer is not intended and, therefore, is not described in this instruction. Repairs of **gear, motor, brake or speed encoder** shall be carried out only by the manufacturer of the respective components or after consulting with the manufacturer or with Loher GmbH, Ruhstorf.

The operating instruction in its actual version is part of the supply of the driving systems **DYNASYS®S**. The nominal data of the motor and the brake may differ, depending on the kind of application. To the system actually supplied, always the respective nominal data on the type plate are applicable.

Any work dealing with transport, connection, commissioning and maintenance is to be carried out by qualified and trained personal (observe prEN 50110-1/VDE 0105, IEC 364)

This operating instruction is intended to ensure safe working conditions during installation and maintenance of the driving system. The operating instruction and the separate instruction for the brake shall be available for installation and commissioning of the driving system as well as for maintenance work in complete and well legible condition.

This operating instruction can be downloaded from the Internet under address:

<http://www.loher.de>

Scope of supply

The actual project-related scope of supply can be taken from the documents delivered along with the material.

Scope of supply, unless ordered otherwise:

- frequency inverter DYNAVERT® L05 (separate instruction)
- permanent-field synchronous driving motor
- traction sheave, mounted to the A-side of the motor
- dual-circuit disc-brake mounted to the B-side of the motor
- sin/cos speed and position encoder with socket for connection of the signal cable-plug, mounted to the B-side of the motor
- screened cable to connect the speed encoder to the frequency inverter DYNAVERT® L05

Introduction and general notes

Additional supplies upon request:

- Brake lifting device with USD for electrical brake lifting
- Base frame with or without diverter pulley
- Set of cables with screened motor-cable and unscreened cables for brake and motor thermistors

Documentation

Included in the package of the drive **DYNASYS®G** one copy each of the following documents is supplied:

- this operating instruction
- operating instruction for the brake
- operating and commissioning instruction for the frequency inverter Loher **DYNAVERT® L**

The documents listed below are sent to the company address of the customer:

- this operating instruction with EC type examination certificate for the brake
- calculation results for rope traction and rope safety factors as per EN 81, acc. to the lift data specified by the customer
- the required declarations of conformity

Additionally, connection diagrams are contained in the motor terminal box for:

- motor and motor protection,
- brake coil and brake monitoring contacts

Type plates and type codes

General notes

Each drive unit is fitted with minimum two type plates:

- a) Type plate 1 shows the motor data
- b) Type plate 2 shows the data of the complete drive with brake and encoder.

If the rating of the driving unit, related to the traction sheave, was carried out by Loher and if the sheave was supplied by Loher, the type code of a third type plate indicates the groove profile of the traction sheave.



Further type plates of the respective manufacturer are fixed to the brake and to the speed encoder.

Example of type plate 1 - Motor:

		Made in Europe		FLENDER LOHER	
Art.-Nr.:	0222222-0001	FN	500 000		
Motortype SVM 250-15.1					
P	14,4 kW	Betr.Art/duty	S1		
f _n	16,5 Hz	n _n	110 min ⁻¹		
U	400 V	M _n	1250 Nm		
I _n	33,4 A				
Iso-class	H	Schutzart/encl.	IP 23		
Kühlart/cooling	IC 06	Masse/mass	540 kg		
WA	7759	Bauj./produced	2005		

Legend of type plate 1:

Art. Nr.	Serial no. of the order	M _n	Rated torque
FN	Motor serial no.	I _n	Rated current
Motortype	Motor type	Iso-class	Insulation class of motor windings
P	Rated power with nominal speed	Schutzart/encl.	Mechanical motor protection
Betr.Art/duty	Duty classification	Kühlart/cooling	Kind of motor cooling
f _n	Rated frequency	Masse/mass	Mass of motor without brake, encoder and traction sheave
n _n	Rated speed	WA	Winding specs./ regulation
U _n	Rated voltage	Bauj./produced	Year of production

Example of type plate 2 – Complete drive

		Made in Europe		FLENDER LOHER	
EP-Nr.	1090202-0003	Ser.Nr.	7 200 000		
DYNASYS S [®] ANTRIEB / DRIVE Type: 8S4A-02400-014250151					
Bremse/brake	ROBA stop - RSO 1300				
P _n	2 *130 W	U _n	2 * 207V-DC		
Geber/enc.	sincos analog	Impulse/360	2048		
Offset:	1600	Impulse abs	1		
		Masse/mass	670 kg		
n-Betr./-oper.	43 min-1	Bauj./produced	2005		

Type plates and type codes

Legend of type plate 2:

EP.Nr.	Serial no. of the final product	Geber/enc.	Pulse shape of speed encoder signals
Ser.Nr.	Serial no.	Impulse/360	No. of pulses of the speed encoder track
Type	Type code	Offset	Factory-set value for the zero-position of the encoder, related to the rotor position
Bremse/brake	Type of the brake installed	Impuls abs	No. of pulses of the encoder track to establish the rotor position
P _n	Rated power of brake coils	Masse/mass	Weight in kg
U _n	Rated voltage of brake coils	n-Betr./n-oper.	Operating speed
		Bauj./produced	Year of production



The operating speed (adjustment speed for the inverter) „n-Betr.“ is indicated only if the system is completely supplied by Loher - incl. the traction sheave.

Type code of type plate 2:

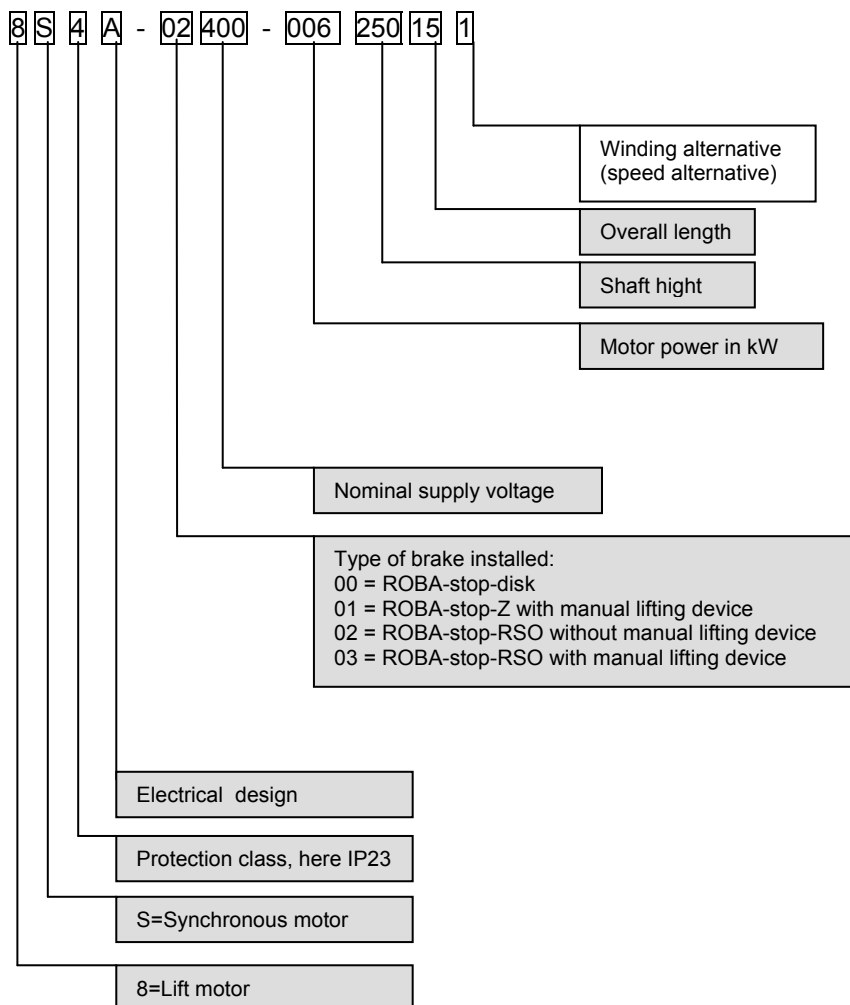

Type plates and type codes

Example of type plate 3 – Traction sheave:

(only if the traction sheave is supplied by Loher)

		Made in Europe		FLENDER LOHER	
Art.-Nr.:		0222222-0001			
Treibscheibe / traction sheave SVM-TS -0400-08*10/17- R095-35-140					
D _n	400 mm	Seile/ropes:	10 mm		
	Rillenform/shape of grooves		R		
Beta	95 °	Gamma	35 °		
RA	17 mm	KB	140 mm		
Härte/hardened	H	Masse/mass	50 kg		

Legende Typenschild 3:

Art.Nr.	Serial no.of traction sheave	Beta	Undercut angle
Type	Type code/design	Gamma	V-angle
D _n	Diameter	RA	Groove spacing
Seile/ropes	Rope diameter	KB	Width of rim
Rillenform/ shape of grooves	Shape of grooves	Härte	H=hardened, otherwise void
		Masse/mass	Mass of traction sheave

Typenschlüssel 3:

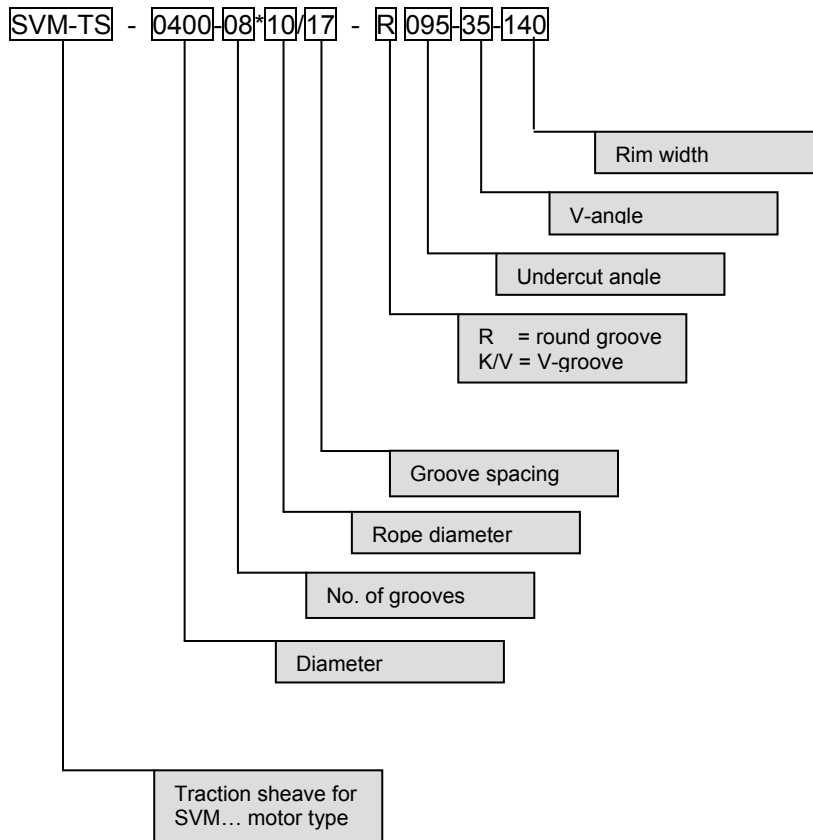

Legal provisions

General notes

At the time of printing, the contents of this operating instruction was up to date. Claims on already supplied drives basing on information contained in this operating instruction can not be asserted.

Intended use

The system described in this operating instruction is intended only for the operation of passenger and goods lifts. DYNASYS® S systems may be used only for the ordered and confirmed purpose, and only under the operational conditions prescribed in the operating instruction. Operation beyond the capacity limits is not permitted.

Warranty

Claims for warranty are to be reported to Loher GmbH, Ruhstorf immediately after the failure or fault was disclosed. For warranty claims the conditions of sales and delivery of Loher GmbH shall apply.

Damages in transport

The drives are leaving the factory in perfect condition. Upon arrival, this perfect condition is to be verified. If it is found that any damages were caused by transport, a claim is to be issued in the presence of the forwarder. Depending on the extent of the damage, commissioning shall be excluded resp. shall not be carried out without consultation with Loher GmbH, Ruhstorf.

Safety instructions

General notes

- These safety instructions shall not be considered complete. In case of any queries please contact Loher GmbH, Ruhstorf
- At the time of delivery the drive complies with the state-of-the-art and is considered safe-to-operate.
- If the calculation of rope traction and rope safety was carried out by Loher the following is to be noted:
 - a) The calculation is made always on the basis of the lift data submitted by the customer.
 - b) The results, including the lift data on which the calculation was based, are handed to the customer after technical clarification, however along with the order acknowledgement at the latest.
 - c) If in execution of the respective project any deviation from these data is made, the results of the calculations become void. In this case Loher will reject any liability for the safe operation of the lift installation.
- The drive shall be operated only in an unobjectable condition. In case of failures or of a rise of the operating temperature it is to be shut down immediately.
- Basically, modifications or alterations of the drive are not permitted.



When working at the driving system ensure that the lift is at standstill and disconnected from the electrical supply. The lift is to be prevented from being re-engaged inadvertently as long as the work is going on.



Usage of the driving unit as the mass point for welding is not permitted.



Under certain operating conditions an increased surface temperature may be developing. Caution! Risk of burns!



During operation, life-threatening high voltage may occur at the motor terminals.



The settings of the frequency inverter contributing to the operational safety are imperative.

Safety instructions

Persons responsible for safety

a) User

"User" means any natural or legal entity using the drive, or on whose behalf the drive is used. The user resp. his safety engineer has to guarantee,

- that all applicable regulations, notes and laws are complied with
- that only qualified personnel is working at drive
- that this operating instruction is available to the personnel
- that unqualified persons are forbidden to carry out any work at the drive

b) Qualified personnel

Qualified persons are persons who - owing to their education, experience, training and knowledge about the relevant standards and regulations, accident preventing instructions and operational conditions - have been authorized by the person responsible for the lift safety to carry out necessary actions and to identify and avoid possible hazards (definition for qualified persons acc.to IEC 364)

Operating conditions for DYNASYS®S drives...

- **DYNASYS®S** drives are intended for operation in lift installations only
- **DYNASYS®S** drives are not allowed to be operated in areas subject to explosion hazards or in an aggressive atmosphere containing unusual quantities of dust, acids of corrosive substances or gases
- The ambient temperature during operation may be within -5°C and $+40^{\circ}\text{C}$. This does not apply to the frequency inverters. For these the conditions of the specific operating instruction shall apply.
- The data specified on the type plate apply only up to an altitude of $\geq 1000\text{m}$ above sea level. In altitudes beyond that a power loss will occur.
- The relative air humidity shall not exceed 50% at an ambient temperature of 45°C , and 90% at 20°C .
- **DYNASYS®S** drives to be installed only in fully enclosed and dry rooms, declared as electrical machine room.



The admissible load applying at the traction sheave depending on the supported masses, shall not exceed the limiting values of the admissible shaft load.

The admissible shaft load may be taken from chapter "Technical data" in this manual.



The motor shall be operated only with a frequency inverter. Direct connection to the electrical supply system may result in its destruction.

Description of the product

Transport



For the transport of the drives appropriate hoists and load suspension means with sufficient capacity are to be used. Here, the total mass of the complete driving unit, possibly mounted on a base frame, is to be considered. To determine the total mass from the tables below, the mass of the respective motor type and the mass of the traction sheave must be added. The calculated weight may differ slightly from the real weight of the supplied driving unit. The actual installation-related weight is indicated on the type plate of the supplied driving system. The actual installation-related weight, including the built-on brake, is indicated on the type plate of the driving unit.

Table 1: Weights

Motor type	Weight of motor without base frame	Brake ROBA-stop® Silenzio	Weight of brake Version without manual brake lifting device	Weight of brake Version with manual brake lifting device
SVM 250-04	285kg	Size 500	60kg	ca. 65kg
SVM 250-06	325 kg	Size 500	60kg	ca. 65kg
SVM 250-08	390 kg	Size 800	92kg	ca.102kg
SVM 250-10	430 kg	Size 800	92kg	ca.102kg
SVM 250-13	555 kg	Size 1300	126kg	ca.140kg
SVM 250-15	593 kg	Size 1300	126kg	ca.140kg

Table 2: Weights of traction sheaves with 6 grooves

Traction sheave diameter	400mm	440mm	520mm	610mm
Mass	approx. 50 kg	approx. 60kg	approx. 75kg.	approx. 125kg.



For the transport shall be considered that the weight of the traction sheave mentioned in table 2 depends on the actually required number of rope grooves and the width of the traction sheave rim resulting therefrom. Therefore, the actual weight may deviate slightly upwards or downwards.



Fig. 1: Motor SVM 250 shown with sling ropes fixed to the lifting eye bolts of the motors.



The lifting eye bolts to be checked for tightness before lifting.

Description of the product

Frequency inverter



The operating instruction of the frequency inverter DYNAVERT® L05 is not included in this manual. There is a separate manual attached to the supply.

The speed of the driving system **DYNASYS® S** is controlled by frequency inverter type **DYNAVERT® L05**.

These inverters are the wall mounted enclosed type with protection class IP 20. Installation in a control cabinet together with the lift control is not required. **DYNAVERT® L05** frequency inverters are separate power section units with integrated motor contactor, EMC-filter, brake resistor, mains input filter and motor filter. Thus, the devices fulfill the currently applicable regulations regarding EMC and mains interference.

By this concept not only the reliable separation of power section and lift control is provided, also safe operation against incoming and outgoing interference (EMC) is guaranteed.

Triggering from the lift control is effected either by parallel signal lines via terminal connections or by a serial interface. In this case, the signal transmission is effected through a DCP-protocol. As an option, a signal-converting board (slot-x26) for the control-side shaft information system is available which converts the speed encoder signals to the output terminals as 5V square-wave signals, for further processing.

Motor

The motors of system **DYNASYS® S**, designated as type SVM 250-..., are 18-pole permanent-field synchronous motors. The sub-assemblies of the motor are composed as follows:

Stator	Traction sheave
Rotor	Electro-mechanical brake
Front bearing (A-side)	Position and speed encoder
Rear bearing (B-side)	Forced ventilation
Terminal box	

Stator

Into the welded stator casing the coiled stator package is pressed in. The magnetic circuit consists of electric sheet steel of M400-50A quality. Into the stator slots the star-connected a.c. windings are embedded. The ends of the windings are taken out to the terminal box and connected to terminals U; V; W.

Into the end windings a thermal switch and a thermistor are wrapped in. The thermal switch is to engage the forced ventilation if a winding temperature of 60°C is reached. The connecting wires of the thermistors (PTC) are taken out into the terminal box and connected to the terminals. The thermistor operates at a winding temperature of 155°C. These connections are to be connected to an appropriate thermistor-triggered device in the inverter or in the lift control.

Description of the product



In inverter model DYNAVERT® L the appropriate thermistor trigger function acc. to EN 81 is already integrated so that the thermistor can be connected directly to the terminals at the inverter provided for that purpose.

Rotor

The rotor shaft is of steel acc. to DIN 49CrMo4, HRC min. 28. The rotor package of sheet steel, which is of the same quality as that of the stator, is mounted to the shaft. The sheet package is held together by two end plates and six threaded bolts M10.

The two free shaft ends are provided with keyways, at the A-side to fit the traction sheave and at the B-side to fit the electro-mechanic brake. On the surface of the rotor the permanent-magnets Nd-Fe-B are glued on. Additionally, the magnets are secured by a bandage of Res-i-Glas.

Bearing B-side

The bearing zone is composed of the welded end shield and a deep-groove ball bearing. The end shield is fixed to the stator with 8 hexagon socket screws M8x20. Between bearing and end shield the bearing key is laid in, allowing an axial play of the rotor.

Bearing A-side

The bearing zone is composed of the welded end shield and a ring-cylinder bearing.

The end shield is fixed to the motor casing by 8 hexagon socket screws M8x20 and the inner bearing cover to the end shield with 6 hexagon socket screws M8x30.

Forced ventilation

The forced ventilation unit G2E140-AE77-01 (EBM Mulfingen) for cooling of motor windings is fixed to the upper side of the stator by 4 hexagon socket screws M6x30.

The starting capacitor is in the motor terminal box. The forced ventilation is operated by the thermostatic switches wrapped-in into the stator end winding. Triggering at 60°C winding temperature.

The sucked-in cooling air is blown out through two output openings with air slots at the underside of the stator.

Terminal box

The terminal box is located on the stator case. Depending on the overall length of the motor it is mounted either completely on the motor casing (from SVM 250-08 upward) or about equally on the motor casing and the protective cover of the brake. Sufficient holes and auxiliary holes for the required cable connections are available. Upon delivery all holes are fitted with plastic covers. These are to be replaced by cable fittings where a cable is led in. Unused openings to remain covered.

Description of the product

Speed and position encoder



As speed and position encoder type ERN 1387, make Heidenhain, is used. It is mounted at the B-side of the motor within the boring of an intermediate flange that is fixed to the brake by means of resilient torque brackets with bolts M5. The pulse shape of the encoder is sine-cosine with 2048 periods per motor revolution for the speed detection. A 2nd signal track with 1 period per revolution is evaluated for the detection of the rotor position. Connection by circular plug with pin contacts. Counterpart is a socket connected to the encoder by a short piece of cable, to be considered a fixed component of the encoder.



For connection a cable with plug at both ends, offered by Loher, should be used to avoid faulty connections which possibly may cause damage of the encoder.



After changing the encoder establish anew the rotor position of the motor. This is to be carried out with ropes taken off via the menu of the frequency inverter (see operating instruction DYNAVERT[®] L05).

Traction sheave

The one-piece traction sheave is made of GG30 with a hardness of 220 to 240HB. Depending on the order it is additionally surface hardened up to 50HRC. No. and shape of grooves is carried out acc. to the specific lift requirements and are basing on the calculations of rope traction, rope safety and on customer's demands. Appropriate traction sheave clamps are delivered upon request .

The traction sheave is fitted to the conical shaft end of the A-side of motor. Disassembly is carried out also the cold way by turning in the bolts which are propping up against the shaft end of the rotor, thus allowing to force-off the traction sheave easily from the shaft.

Several types of standard traction sheaves of different rim width are available.

Description of the product

Table: Standard traction sheaves

Nominal diameter (mm)	Maximum no. of grooves	Possible rope diameter (mm)	Width of rim (mm)
320	6	up to 8mm	100
400	4	up to 10mm	90
400	6	up to 10mm	120
440	6	Up to 11mm	120
520	4	up to 13mm	90
520	6	up to 13mm	120
610	6	up to 14mm	136

Brake

At the B-side shaft end of the motors a brake ROBA-stop[®]- Silenzio[®] (make Mayr) is mounted. The brake is available in 2 different versions. Which version is used depends on the demands of the customer resp. on the range of application, depending on the lift system.



The operating instruction for the brakes is not part of this manual. The manufacturer's (Mayr) original version is supplied as a separate document.

Brake versions

- a) Brake without manual brake lifting device, preferably for the use in installations without machine room.
- b) Brake with manual brake lifting device, preferably for the use in machine rooms (drive unit not mounted in the shaft).

The brake ROBA-stop[®]- Silenzio[®] is a spring operated dual-circuit brake with two brake units and brake coils working independently from each other. Each brake coil can be excited individually, thus enabling the check of the dual-circuit function also via remote operation by a key.



The connected voltage of each brake coil is 207VDC



Either of the two brakes is equipped with a micro-switch to monitor the brake lifting. The contacts of the microswitches are to be connected in the lift control according to the instructions of the manufacturer of the control.



Check of dual-circuit function is effected by gauges belonging to the scope of supply of the brake. The brake is approved as a protective device against overspeed in upward direction acc. to EN 81.

Installation and operation of the drive unit



Mount the drive unit only in the mounting position as ordered. The indications on the type plate are to correspond with the values of the order, confirmed by Loher. In particular the following values:

- traction sheave diameter
- shape of grooves of traction sheave
- width of undercut and angle γ (v-angle) in case of traction sheaves with round grooves
- angle γ in case of traction sheaves with v-groove
- rope groove corresponding to the rope diameter
- no. of ropes
- supply voltage



The driving unit shall be mounted only in fully enclosed and dry lift machine rooms which comply with the current lift directives.



Alignment of driving unit with base frame horizontally, of traction sheave vertically.



The driving unit shall be operated only within the limits of ambient temperature of -5°C to 40°C .



Operation in areas subject to explosion hazards or with an aggressive atmosphere is not allowed.



The cooling flow for the motor fan may not be obstructed. The inlet opening at the fan and the outlet opening at the motor casing are to be checked regularly and to be kept unobstructed.



The electrical connections are to be protected against accidental contact.



An additional isolation of the base frame by means of rubber-metal elements is not imperative.

Electrical connections

General notes

Except speed and position encoder all connections at driving unit DYNASYS® S to be made in the motor terminal box.



Electrical connections, also of the thermistors, to be made only with installation in dead condition.



The test voltage for the thermistors shall not exceed 2,5V. In case of a possibly required continuity test, an appropriate voltmeter shall be used.



Only an appropriately screened cable shall be used for the supply from the frequency inverter to the motor. Strip the insulation off the screen at the motor end, so that the screen is completely gripped by the supplied metal cable fitting and a large-sized contact area is provided.



Dynasys® S driving units with brake ROBA Stopp Z are supplied with a quick-action rectifier mounted in the motor terminal box. The connected voltage of the quick-action rectifier of 400VAC is to be observed. The otherwise usual rectifier in the lift control can be omitted.



Upon request, Loher will also supply the appropriate motor cables.

Electrical connections

Motor terminal box

a) Connections of brake ROBA- Stop®- Silenzio®

Terminals with factory-wiring

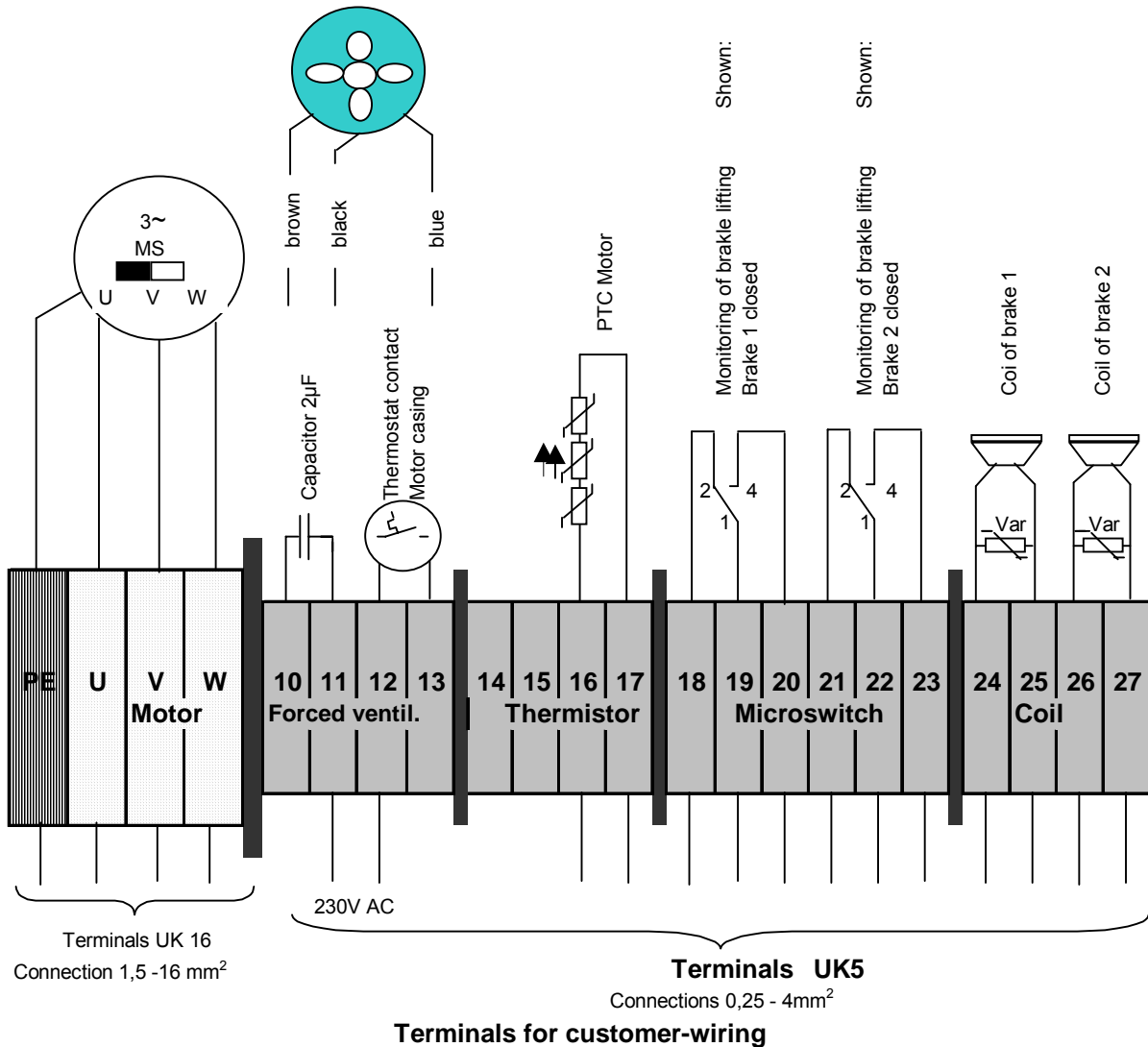

Protective wire (green/yellow) of motor to be connected to the earthing terminal in the motor terminal box, with good contacting. Cable with cross-section corresponding at least with the feeder cable cross-section of the motor connections U,V,W.



The screened motor feeder cable to be lead-in through the metal fittings and the screening to be brought in good contact with the fitting so as to get a large-sized area of contact.

Electrical connections

Phase sequence

With correct phase sequence U,V,W the motors shall rotate clockwise (with view to the outer side of the traction sheave).



The motor must always be connected in-phase. If it is necessary to change the direction of rotation owing to lift-related circumstances, this is to be done only by resetting the parameters of the frequency inverter.

Speed and position encoder



The speed encoder is connected to the inverter DYNAVERT® L05 by a pluggable cable included in the supply.

The motor-side circular plug is to be plugged into the respective socket directly at the speed encoder and to be arrested with the screwed cap.

The other end of the cable is provided with a Sub-D plug, which is to be plugged into socket X25 at the inverter Dynavert®L05.

Socket to connect the cable of the speed and position encoder



Plug and socket are coded by tongue and groove, so that they can be plugged together in correct position only. Plug and socket shall never be forced together.

Pin assignment of the coupling with contact pins

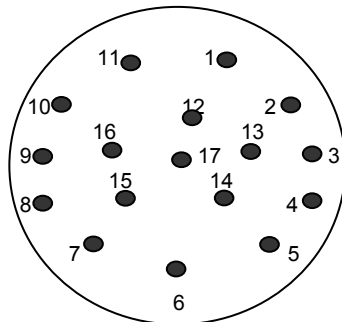

Table: Meaning of the pins

Pin	Signal	Pin	Signal
1	A+	10	Up+
2	A-	11	B+
3	R+	12	B-
4	D-	13	R-
5	C+	14	D+
6	C-	15	0V Sensor
7	0V	16	Up Sensor

Technical data

Motor

Table1: Motor data

Sizes	S	S	M	M	L	L
Type SVM 250...	04	06	08	10	13	15
Torque in case of fan cooling, S1 operation	350Nm	520Nm	700Nm	880Nm	1100Nm	1250Nm
Torque with 240 starts/h, S3-75% CDF	400Nm	600Nm	820Nm	1020Nm	1270Nm	1450Nm
Torque with 180 starts/h, S3-55% CDF	475Nm	700Nm	950Nm	1200Nm	1475Nm	1675Nm
Maximum torque $M_{\dot{u}_{max}}$	870Nm	1300Nm	1750Nm	2150Nm	2800Nm	3100Nm
Capacity of torque overload $M_{\dot{u}_{max}}/M_n$	ca. 2,5					
Moment of inertia of rotor	0,9kgm ²	1,2kgm ²	1,5kgm ²	1,9kgm ²	2,3kgm ²	2,6kgm ²
Mass w/o traction sheave	245kg	385kg	485kg	525kg	700kg	730kg
Admissible radial load	max. 50kN				70kN	
Bearing type A-side	Self-aligning roller bearing SKF 22219 E/C3				SKF 22224 E/C3	
Bearing type B-side	Deep-groove ball bearing SKF 6218 2RS1/C3				SKF 6220 C3	
Shaft diameter A-side	90mm				120mm	
Shaft diameter B-side	65mm with brake RSO 500 and 800				85mm with brake type RSO 1300	

Construction	IM 1001 acc. to EN 60034-7
Maximum speed	300 rpm
Absolute limit of demagnetization	Maximum torque $M_{\dot{u}_{max}} \times 1,1$ at winding temperature 140° C
Type of forced ventilation	G2E 140-AE77-01, 230VAC
Type of brakes	Make Mayr: dual-circuit brake ROBA-Stop® Silenzio
Winding protection	PTC thermistor 155° C
Cooling	IC06
Protection class	IP23
Insulation class	H
Vibration severity	Effective 1,12mm s ⁻¹
Nominal voltage	400Veff – 540VDC (intern. circ.) at nominal speed
Paint finish	RAL 5002 silk-mat



Motor footing, motor shaft and welding seams allow rope forces to act in downward and upward direction (see sketch below).

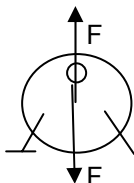

Technical data

Table 2: Elektrical motor data

Motortyp SVM 250	f [Hz]	n _N [min ⁻¹]	n _{Nutz} [min ⁻¹]	n _c [min ⁻¹]	I _N [A]	I _{ümax} [A]	P _N [kW]	Q [kJh]
-04.7	5,4	36	58	10	5,6	14,9	1,3	5267
-04.3	9,0	60	69	20	6,4	16,9	2,2	5385
-04.1	16,5	110	117	60	9,7	25,7	4,0	5504
-04.4	25,0	167	184	110	14,2	37,8	6,1	5746
-04.2	28,5	190	195	117	15,1	40,2	7,0	6166
-04.5	35,7	238	247	155	18,6	49,4	8,7	6221
-04.6	42,9	286	295	190	22,0	58,4	10,5	6645

-06.7	5,4	36	52	104	7,1	19,0	2,0	6407
-06.3	9,0	60	74	33	9,4	25,1	3,3	6818
-06.1	16,5	110	118	67	13,8	37,0	6,0	6869
-06.4	25,0	167	174	109	19,6	52,4	9,1	7454
-06.2	28,5	190	191	121	21,4	57,1	10,3	7759
-06.5	35,7	238	259	171	28,2	75,4	13,0	8132
-06.6	42,9	286	311	208	33,6	89,8	15,6	8759

-08.7	5,4	36	51	18	9,0	24,2	2,6	7778
-08.3	9,0	60	70	32	11,7	31,4	4,4	8352
-08.1	16,5	110	117	69	18,1	48,4	8,1	8622
-08.4	25,0	167	175	112	26,1	69,9	12,2	9574
-08.2	28,5	190	199	130	39,4	78,6	13,9	9761
-08.5	35,7	238	256	172	37,2	99,3	17,4	10127
-08.6	42,9	286	287	195	41,5	111	21,0	10950

-10.7	5,4	36	51	21	11,2	29,3	3,3	9369
-10.3	9,0	60	66	32	13,8	36,2	5,5	9992
-10.1	16,5	110	122	75	23,5	61,5	10,1	10906
-10.4	25,0	167	181	121	33,6	87,8	15,4	11353
-10.2	28,5	190	202	136	37,2	97,0	17,5	11624
-10.5	35,7	238	258	177	47,1	123	21,9	12855
-10.6	42,9	286	301	209	54,3	142	26,4	13307

-13.7	5,4	36	42	14	11,8	32,2	4,1	10982
-13.3	9,0	60	68	35	17,3	47,1	6,9	11344
-13.1	16,5	110	119	74	28,1	76,6	12,7	12232
-13.4	25,0	167	173	114	39,7	108	19,2	13595
-13.2	28,5	190	198	134	45,0	123	21,9	13477
-13.5	35,7	238	250	172	56,3	153	27,4	14629
-13.6	42,9	286	303	211	67,6	184	32,9	15698

-15.7	5,4	36	41	15	13,0	34,5	4,7	17421
-15.3	9,0	60	64	34	18,4	48,9	7,9	16448
-15.1	16,5	110	118	77	31,6	83,8	14,4	15466
-15.4	25,0	167	170	116	44,3	117	21,8	14782
-15.2	28,5	190	198	137	51,1	135	24,9	13394
-15.5	35,7	238	236	166	60,4	160	31,1	15316
-15.6	42,9	286	292	208	73,8	196	37,4	14980

Remarks on table 2:

- n_{Nutz} is the calculated maximum achievable speed with M_N
- n_c is the calculated minimum achievable speed with M_{max}
- the indicated speed ranges have been determined for the maximum motor supply voltage (fundamental wave) U_{1max}=340V.

Technical data

Motor heating

The insulating system is carried out acc. to temperature class EN60034-1, which means that with nominal speed and nominal load the temperature of the windings must not exceed 120° C.

Voltage

The motors are fed with 540VDC, the nominal voltage of the intermediate circuit of the inverter DYNAVERT®L.

Insulation resistance

The insulation resistance of the motor windings, the forced ventilation, the brake, the thermal switch and the thermistors measured in cold condition are not less than 50MΩ.

Electrical stability

The motors withstand an applied alternating voltage of 2000V, 50Hz against the casing without damage of windings, thermistors and thermal switches, with a slewing rate of 1300V/μs

Reluctance torque (Cogging)

The maximum value of the reluctance torque is $\leq 3\%$.

Fatigue strength of the traction sheave shaft

Material of the shaft: 49CrMo4

⇒ Min. safety factor: $s_{\min} = 1,5$

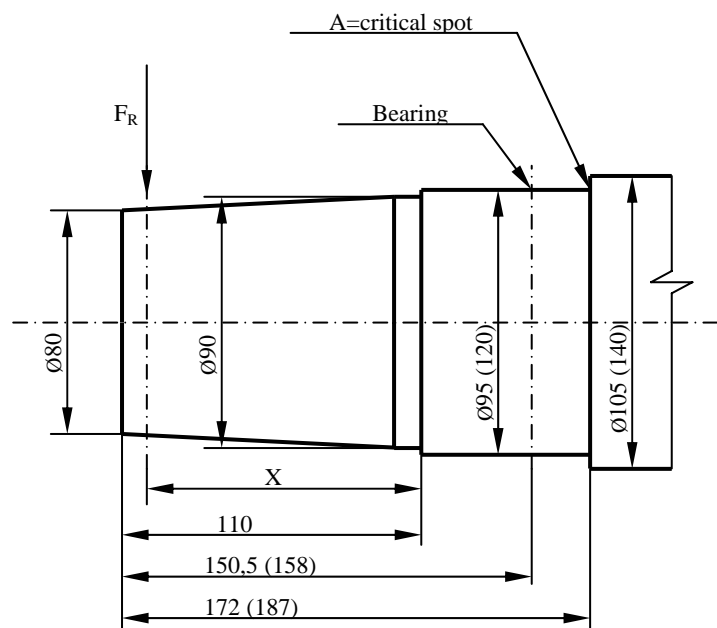

(Values in brackets are valid for size 250-13 and -15)

Technical data

Diagram: admissible loads on traction sheave shaft

Diagram 1: applicable for types SVM 250- 04/06/08/10

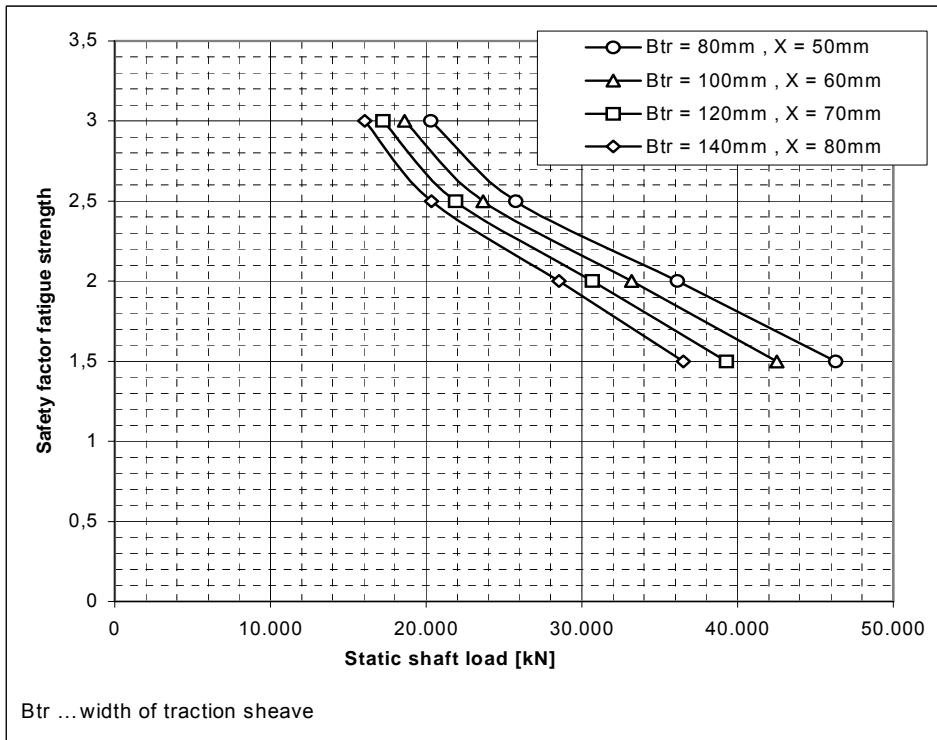
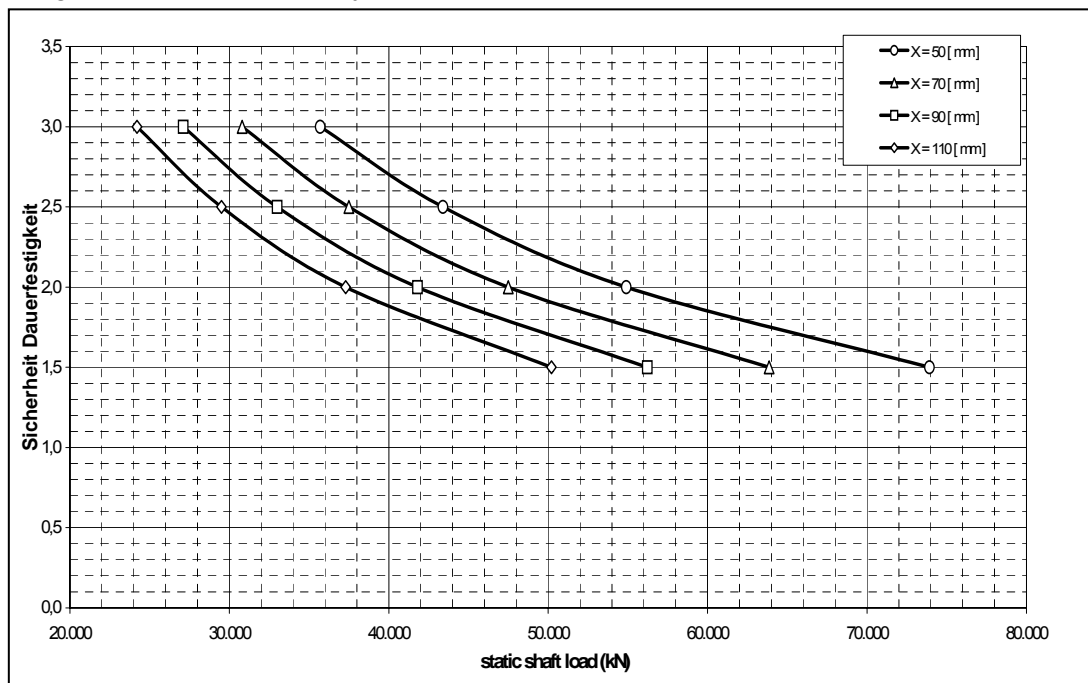

Diagram 2: applicable for types SVM 250-13/15



Technical data

Forced ventilation

Type	: G2E 140-AE 77-01
Manufacturer	: EBM
Voltage	: 230V
Frequency	: 50Hz
Air discharge rate	: 370m ³ /h
Speed	: 1400 min ⁻¹
Power input	: 105W
Current input	: 0,46A
Capacitor	: 2µF
Noise level	: 59dBA
Adm. ambient temperature	: 40° C
Weight	: 2,6kg

Speed encoder

Type	: ERN 1387
Manufacturer	: Heidenhain
No. of strokes	: 2048±20“
Signals	: Sin/Cos
Position value per revolution	: 1 (Z1 track)
Voltage	: 5V±5%
Scanning frequency	: ≥ 200kHz
Current input without load	: ≤ 150mA
Elektrical connection	: 14-pole
Protection class	: IP40
Mech. adm. speed	: ≤15000min ⁻¹
Admissible axial displacement of the shaft	: ±0,5mm
Max. operating temperature	: 120° C
Min. operating temperature	: -40 ° C
Mass	: 0,25kg

Brakes

Table: Assignment brake / Motor

Motor type	Type ROBA-stop® silenzio...	Braking torque
SVM 250-04	Size 500 with 2x380Nm	2x380Nm
SVM 250-06	Size 500 with 2x600Nm	2x600Nm
SVM 250-08	Size 800 with 2x800Nm	2x800Nm
SVM 250-10	Size 800 with 2x1000Nm	2x1000Nm
SVM 250-13	Size 1300 with 2x1300Nm	2x1300Nm
SVM 250-15	Size 1300 with 2x1300Nm	2x1560Nm

Basic technical data:

Designation	: ROBA-stop® silenzio®
Manufacturer	: Mayr
Working principle	: Spring pressure brake
Nennleistung	: Size 500=2x 90W Size 800=2x107W Size 1300=2x130W
Nominal voltage of coils	: 2x207VDC
Relative operating factor	: 100%
Ambient temperature	: -5 to 45°C

Technical data

Protection class, mechanical	:	IP10
Protection class, electrical	:	IP 54
Thermal category of magnet coil	:	F (155°C)
Monitoring of brake lifting	:	Micro-switch contacts
Wear monitoring	:	No
Temperature sensor	:	No
Approved as a protective device for lift travelling upward	:	Yes
Manual brake lifter	:	Optional

Traction sheave

Manufacturer	:	Kasper
Material	:	GG30
Hardness	:	220 to 240HB; Optional surface hardening up to 50HRC
Tensile strength	:	min. 310 N/mm

Maintenance and repair

General notes

Repair work at the site of the lift installation which requires the disassembly of individual components is not intended. In case of wear or defects at the components, these shall either be replaced completely or repaired in a qualified workshop authorized by Loher.

Table 1: Surview on the replacement parts

Driving motor	To be exchanged completely
Forced ventilation	To be exchanged completely
Speed and position encoder	To be exchanged completely
Brake	To be exchanged completely by the manufacturer or by Loher GmbH, Ruhstorf
ROBA switch quick-action rectifier	To be exchanged completely
Traction sheave	To be exchanged completely
Motor terminal box	To be exchanged completely
Cable for speed and position encoder	To be exchanged completely

Disassembly of the speed encoder



Before disassembly switch off the main switch. That means, the lift is to be disconnected from the power supply.

Sequence of disassembly steps:



1. Unplug the cable from the connecting socket and loosen the brace fixing the adapter cable to the encoder.
2. Loosen the hexagon socket screws M5 of the outer holding ring
3. Remove the holding ring.
4. Screw-in a forcing screw of appropriate length into the threaded hole M5 and press out the encoder.



After exchange of an encoder or after reassembly of the same encoder an encoder readjustment is to be carried out in any case. This is performed via an appropriate parameter in the inverter. For that, the motor is to be rotating freely, which means, the ropes are off and the brake is open.

If this is not carried out, a fault-free operation and a reasonable travelling behaviour of the lift is not possible.



The encoder shall be mounted with little force only (don't use a hammer). Shocks may damage the encoder.



The encoder shall not be thrown or dropped.
The connecting cable shall not be laid under mechanical tension.

Maintenance and repair

Disassembly and reassembly of the traction sheave

The traction sheave is fitted to the conical shaft end of the motor the cold way and is pulled-off also without being heated.

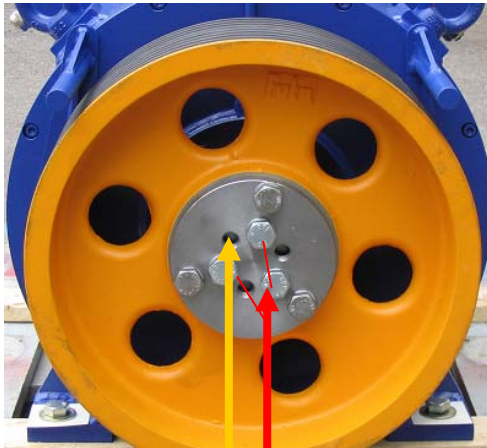

Screw out the 3 inner screws M16 of the securing plate. Screw in the same 3 screws evenly into the treaded holes, thus pressing-off the traction sheave from the motor shaft.

For reassembly screw in the 3 screws for the inner treads evenly.



Screw tightening torque 210Nm

Maintenance

For maintenance and operation of the lift the current regulations of EN 81 and further relevant regulations are to be observed.

Table of maintenance intervals

Check	Intervals
Check of bearing noise	3 months
Check of radial shaft sealing rings for grease leakage	3 months
Check of traction sheave fixation	12 months
Check of rope-jump protection	12 months
Check of traction sheave for the grade of wear of the grooves	3 months
Check of electrical connections	12 months
Check of insulation resistance of the motor	12 months
Cleaning of machine	as required
Check of mechanical fixation of motor to base frame	12 months
Check of brake acc. to the operating instruction	acc.to manufacturer
Check of functioning of the forced ventilation	6 months

Maintenance and repair



The inspection intervals mentioned above are a part of the warranty conditions.

Lifetime of motor bearings

Speed	SVM 250-04/06/08/10		SVM 250-13/15	
	A-side	B-side	A-side	B-side
50 rpm	87979h	103559h	272100	327570
110 rpm	39900h	47072h	123681	148895
190 rpm	23152h	27252h	71605	86202
300 rpm	14663h	17260h	45350	54595

Lubrication

Motor typen SVM 250-04/06/08/10

Before delivery the appropriate quantity of lubricant is filled into the A-side self-aligning roller bearing 22219E/C3.

Change of lubricant is required not earlier than after about 10.000 operating hours only.

Quantity of lubricant : 37g

Lubricant : Mobil Grease 28 oder gleichwertig



For changing the lubricant remove first the traction sheave and the bearing cover.

At the B-side the lubricant is topped up through a lubrication nipple. Relubrication should be made after about 12.000 operating hours.

Quantity of lubricant: 23g

Motor types SVM 250-13/15

All bearings are fitted with a lubrication nipple.

Relubrication A-side: after 12.000 operating hours

Relubrication B-side: after 13.000 operating hours

Lubricant: Mobil Grease 28 or equivalent



In the course of an exchange of the bearing replace both shaft sealing rings as well.



Anti-friction bearing and lubrication:

Under appropriate storage conditions no negative effect on the grease in the bearings is to be expected within two years.



To exchange the bearings the lift is to be put out of operation. Take off the ropes.

Maintenance and repair

Spare parts list

Spare parts	SVM 250-04/06/08/10 Axle load 50kN max.	SVM 250-13/15 Axle load 70kN max
Traction sheave	: Installation-specific	Installation-specific
Fitted key A-side (DE)	: 25x9x14x75A	25x9x14x75B
Self-aligning roller bearing	: SKF 22219 E/C3	SKF 22224 E/C3
Ball bearing	: SKF 6218 2RS/C3	SKF 6220 C3
Outer radial shaft sealing ring A-side (DE)	: RST: 95-120-12 NBR	RST 140-150-12 NBR
Inner radial shaft sealing ring A Seite (DE)	: RST: 105-130-12 NBR	RST 140-170-15 NBR
Outer radial shaft sealing ring B-side (NDE)	—	RST 95-120-12 NBR
Inner radial shaft sealing ring B-side (NDE)	—	RST 120-150-12 NBR
Position and speed encoder	: Heidenhain ERN 1387	Heidenhain ERN 1387
Filter mat for air filter	: EBM 95780-1-5171	EBM 95780-1-5171
Forced ventilation	: EBM G2E140-AE077-01	EBM G2E140-AE077-01
Brake	ROBA [®] -stop-silenzio [®] Type 896.0 Manufacturer: Mayr Braking torque see under "brake"	ROBA [®] -stop-silenzio [®] Type 896.0 Manufacturer: Mayr Braking torque see under "brake"

Fitted key B-side

Brake type	ROBA [®] -stop-silenzio [®] Size 500	ROBA [®] -stop-silenzio [®] size 800	ROBA [®] -stop-silenzio [®] size 1300
Shaft diameter	65k6	65k6	85k6
Fitted key	18h9X11x90A	18h9X11x110A	22h9X14x140A

Storage of the DYNASYS[®] G drive systems

Store the DynasysS[®] S driving units only in a fully enclosed, dry, dust-free and adequately tempered room. The relative humidity shall not exceed 70%. Special packing is not required. Under different conditions, pack the driving units in a plastic foil with moisture-absorbing agents (e.g. Branogel) or in an air-tight welded foil. A protective cover against sunshine and rain is needed. Furthermore, store only on plane areas and in shock-free rooms.

Important actions prior to commissioning

Observe and check before starting the first trip that

- that for safety reasons, the first trip is initiated from the lift control via the recall device.
- that the installation of the driving unit is carried out correctly
- that the data of the DYNASYS[®] S drive, especially the motor power and the traction sheave, correspond with the installation
- that the electrical connections are carried out correctly, in accordance with the operating instruction and the accompanying documentation
- that the connections of the frequency inverter are carried out in accordance with the separately supplied operating instruction.
- that the frequency inverter is parameterised in accordance with the operating instruction.
- that the balancing of the counterweight has been carried out correctly
- **Carry out the parameterisation of the inverter before starting the first trip.**



Very often, the cause for an abnormal motor noise during the first trip is a wrong parameterisation of the inverter or a disregard of the phase sequence of the motor connections.



Electrical safety circuits shall not be bridged



Check the functionality of the forced ventilation before commissioning.

Check list for adjustment DYNAVERT® L05



This quick-reference instruction is an excerpt from the commissioning and maintenance instruction DYNAVERT L05, Version 4BS0516-013-de,

Following conditions must be fulfilled before the adjustment of the frequency inverter (parameterising) is started:

1. Motor connection in-phase?

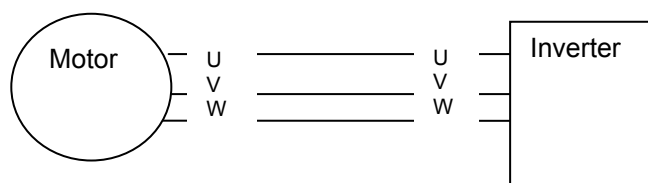

2. Encoder plug at inverter side correctly plugged in socket –x25 and at the motor?
3. Interface to lift control established acc. to the DYNAVERT® L05 operating instruction?

Parameter setting

The following table shows only the parameters required to commission the installation. The settings should be carried out in the sequence shown in the table. The values of the table can be used for travelling speed up to 1,6m/s.

1. Menu level P-Operation

Display	Explanation	Setting
A	Motor type and encoder type : Synchronous motor with encoder ERN1387 or asynchronous motor with HTL encoder or asynchronous motor with TTL encoder	Synch. ERN1387
Menu	By this parameter, the parameters needed for setting according to this table are made available in the display.	Stand.

2. Menu level P-Travel Curve Data

Display	Explanation	Setting
V3	Set the rated speed of the lift	...m/s
V Posi	Levelling speed	0,1m/s
Brk Dist 3	Braking distance to level position	Set here the value indicated in menu I-MIN.BRAKE.DIST. v3
StopDist	Dist. (curve) from switch-off vposi till level position	8cm
Position	Positioning dist. resp. levelling dist. with levelling speed	10cm
Accel.	Value for acceleration hard or soft	0,7m/s ²
Decel.	Value for deceleration hard or soft	0,7m/s ²

2.1 Menu level I- Min.Brake.Dist.

Brk Dist 3	Shows the minimum braking distances calculated by the inverter out of the set value v3.cm
------------	---	---------

Check list for adjustment DYNAVERT® L05

3. Menu level P- Monitoring

Display	Explanation	Setting
V max	Limit for the max. speed. Setting: speed v_3 plus 10%	...m/s

4. Menu level P-System Data

Display	Explanation	Setting
v/n	Operating speed of motor at rated speed of lift, depending on traction sheave and roping. Value v/n from motor type plate	...rpm
Dir-Sign	If terminal X1:37 is active, lift goes downward Check whether control activates terminal x1: only downwards	Down
Motor cw	If the motor phases are connected correctly the motor turns always clockwise, with view to the traction sheave. By this parameter the travelling direction of the lift is adapted to the clockwise rotation of the motor, depending on the position of the traction sheave.	UP or DOWN

5. Menu level P-Travel Behavior

Display	Explanation	Setting
P sp.ctr.	P-component of speed control loop. The value to be set depends on the total masses of the lift. In case of motor noise the factory-set value can be reduced from 15 to about 5, step by step.	Setting between 5 and 15
P sp.ct.pos	As above (P sp.ctr.), influencing however only the starting behaviour during the first motor revolution. Alteration rarely required!	15

6. Menu level P- Motor Data

n-motor	Nominal speed of the motor as per type plate	...rpm
I-motor	Nominal current of the motor as per type plate	...A
f-motor	Nominal frequency of the motor as per type plate	...Hz
V-motor	Nominal voltage of the motor as per type plate	...V
Sensor offset	Zero-position of encoder related to position of motor-rotor. Value (4-digit) is calibrated in the factory and is shown on the motor type plate. In case of encoder modification or exchange the motor is to be recalibrated, without ropes and with brake open. For that, set parameter "Sensor adjustm." to "yes"..	Set the 4-digit numerical value of the motor type plate

Short floor distances or speed higher than 1,2m/s

If the braking distance in all floors or even in one floor only is longer than half of the floor distance "ogival run" is to be set in menu level "TRAVEL CURVE DATA". The calculated minimum braking distances however are extended hereby. Braking distance v_3 to be corrected accordingly.

Perform the first trip in the inspection or recall mode

If the lift is starting, however shuts down shortly after that and showing the fault message **Flt>v-increase**, the phase sequence of the motor connection is wrong.

It may also happen, however, that no fault message appears and that the motor is running with an abnormally loud noise during the whole trip. Also the phase sequence is wrong in most of these cases.

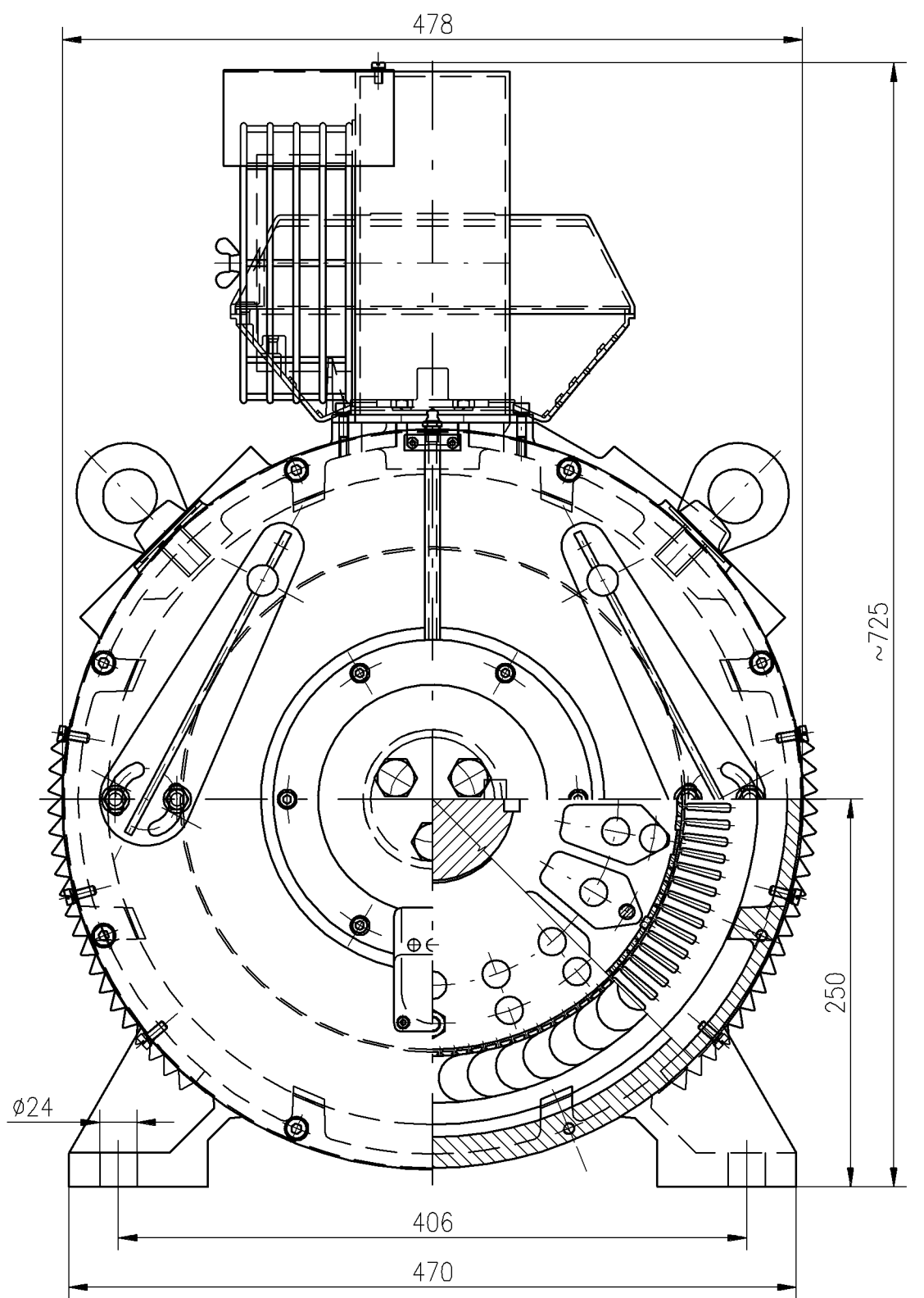
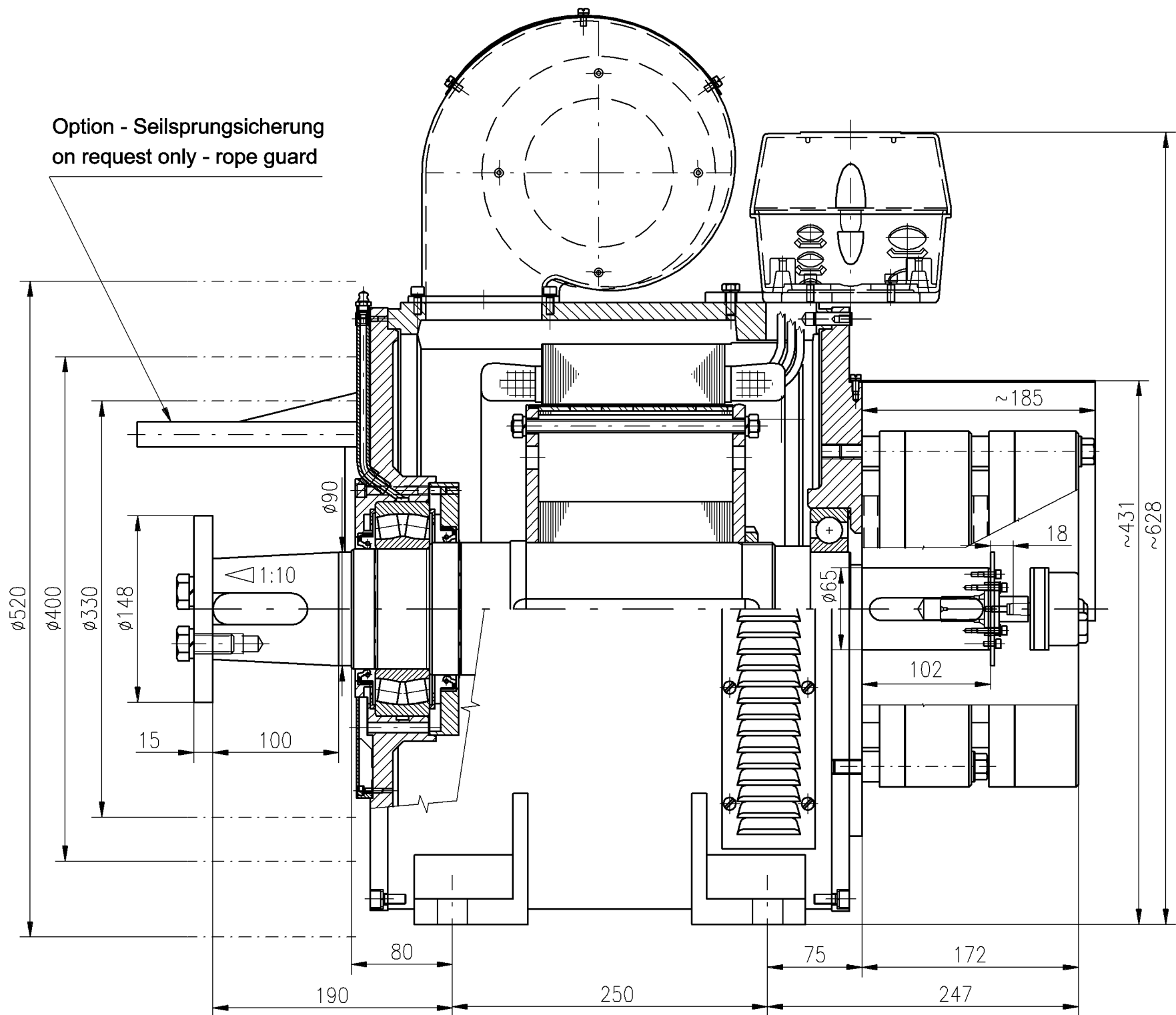

Treibscheibendurchmesser, Kranbreite und Rillenform ergeben sich aus der anlagenabhängigen □
 DYNASYS Antriebsberechnung. □
 Traction sheave diameter, sheave width and form of grooves will be calculated in accordance to the □
 applied lift values.

Werkstoff		Rohteil Zeichng.-Nr.:		Sachnummer		Format	
		Rohteil Sachnummer:		0278655-0001		DIN A	
Allgemeintoleranzen ISO 2768-m		Erstellt		Geändert		Maßstab	
Diese technische Unterlage hat gesetzlichen Schutz (DIN34).		Datum		Datum		1: 4	
Plotdatum		Name		Name		Sprache	
Plotsteller		für Abteilung				de	
Plotstatus		24.8.04		Skupin		Blatt	
		24.8.04		Daniel		1/1	
		Zeichnung-Nr.		8S004DM040-9		Zusatz	
Änd.-Index		Änderungs-Bemerkung					
Teileklasse		FLENDER		Motor SVM 250-04-06			
Ers. für		LOHER		-ROBA stop silenzio 500			
Ursprung		Systemtechnik					

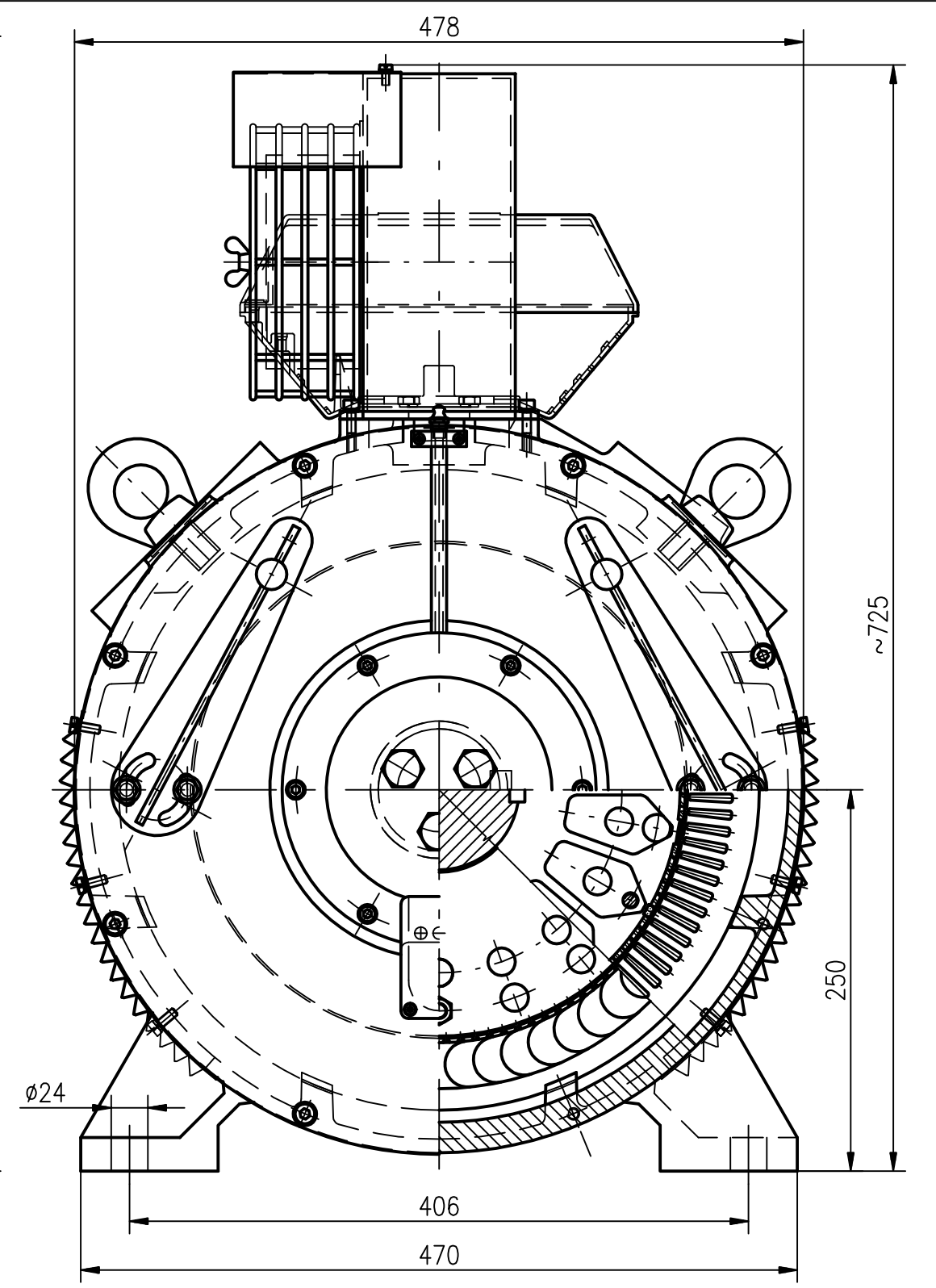
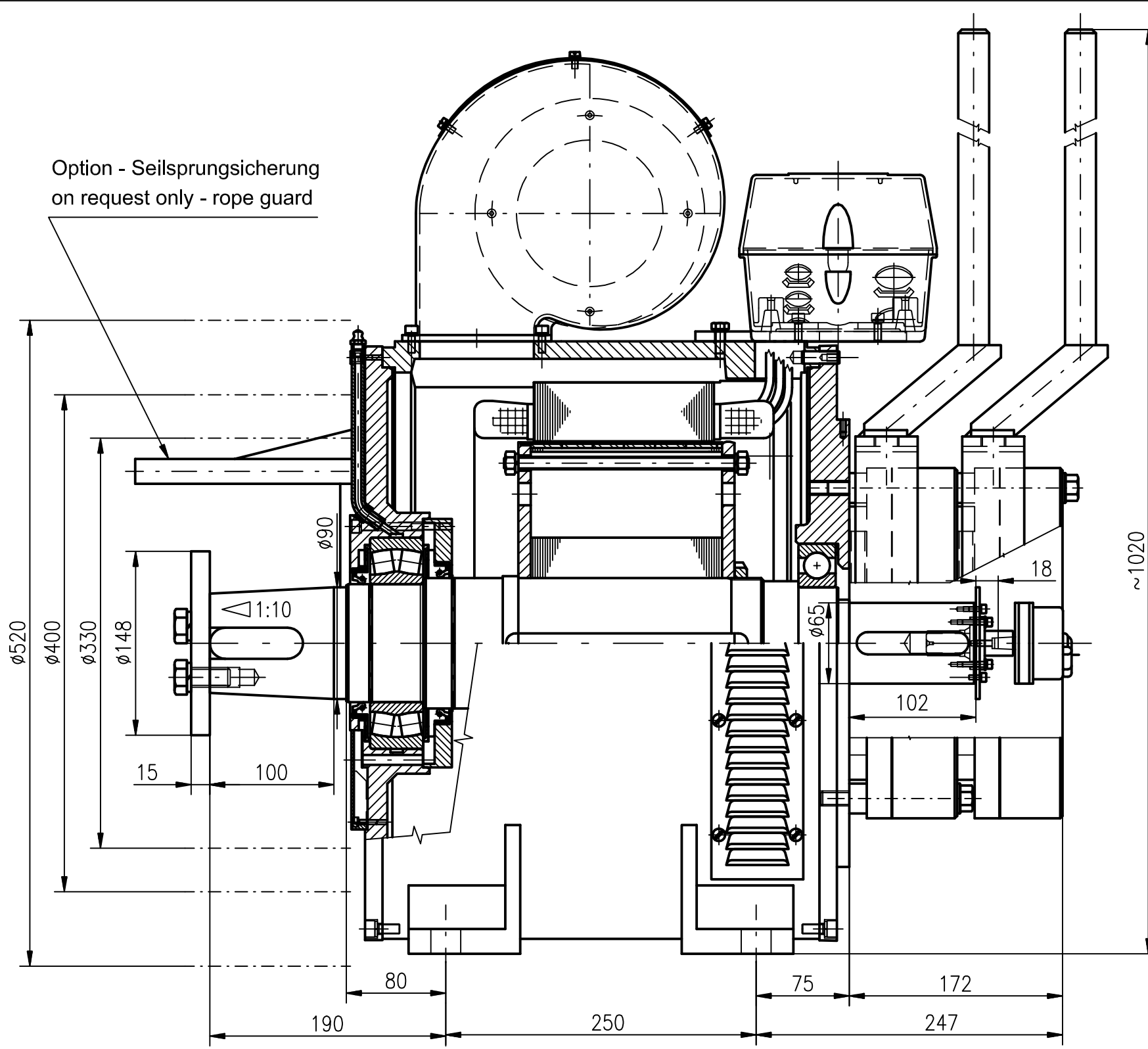

Treibscheibendurchmesser, - Kranzbreite und Rillenform - siehe DYNASYS®-S Antriebsberechnung
sheave-diameter, -width and form of grooves - see DYNASYS®-S drive calculation

Werkstoff		Rohteil Zeichng.-Nr.:		Sachnummer		Format DIN A 3	
Allgemeintoleranzen ISO 2768-m		Rohteil Sachnummer:		Erstellt		Geändert	
Diese technische Unterlage hat gesetzlichen Schutz (DIN34).		Datum		Name		Datum	
Plotdatum		Plotersteller		für Abteilung		Maßstab 1: 4	
Plotstatus		Bearb.		12.5.05		Skupin	
And.-Index		Gep.		12.5.05		Daniel	
Änderungs-Bemerkung		Zeichnung-Nr.		8S004DM041-1		Blatt 1/1	
Teileklasse		FLENDER		Motor SVM 250-04-06		Zusatz	
Ers. für		LOHER		-ROBA stop silenzio 500-HL			
Ursprung		Systemtechnik					

Option - Seilsprungsicherung
on request only - rope guard

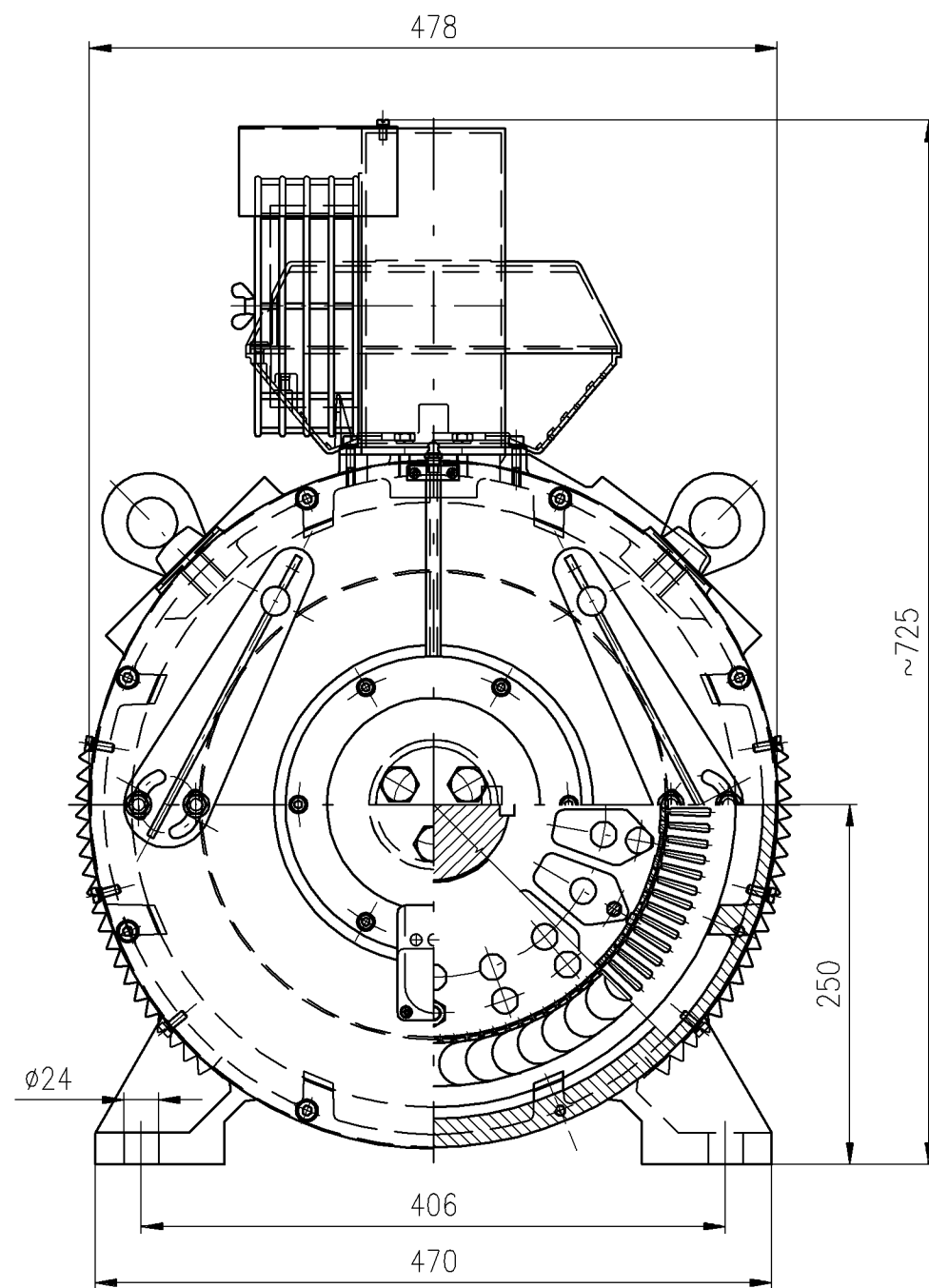
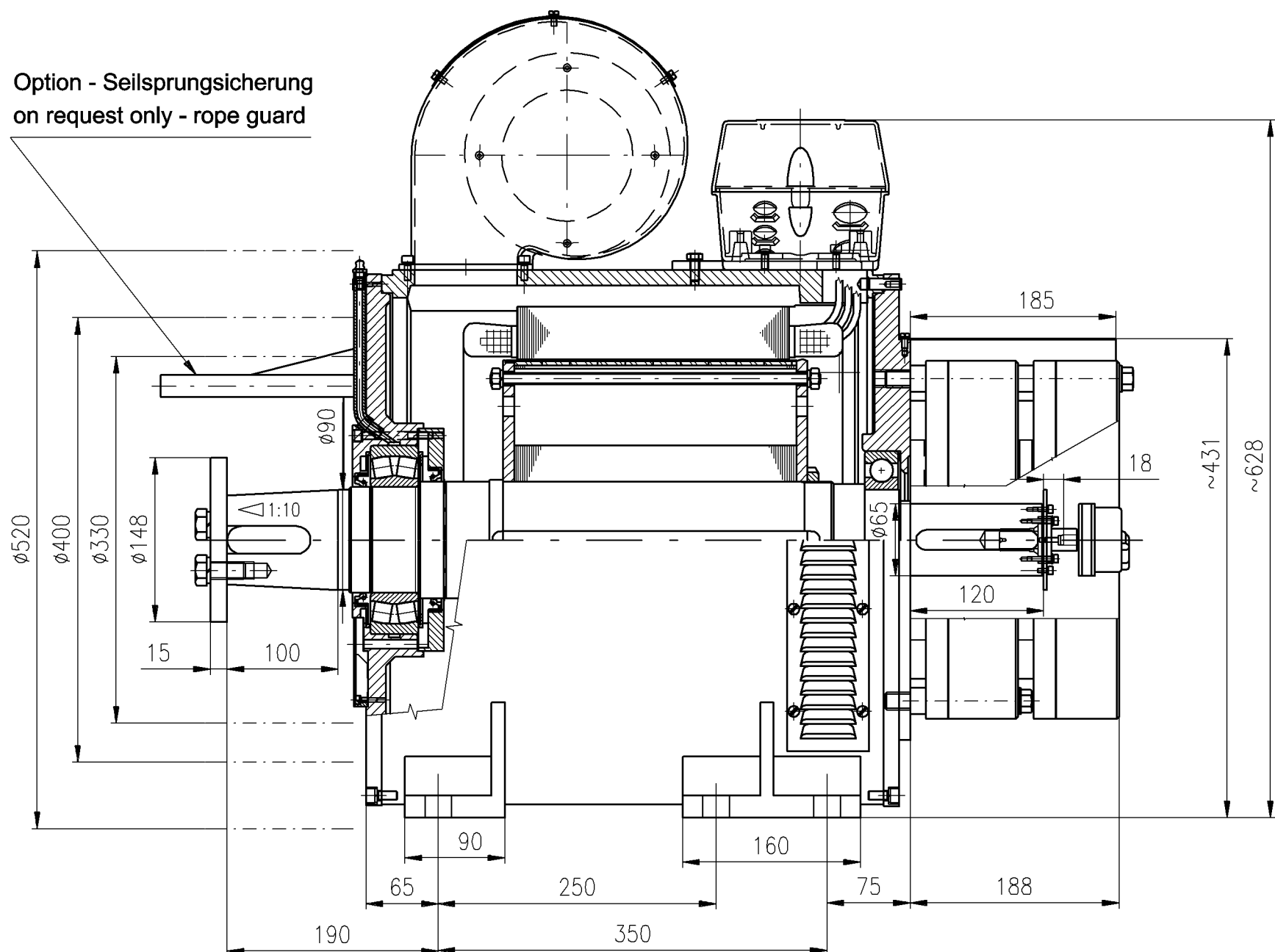

Treibscheibendurchmesser, Kranbreite und Rillenform ergeben sich aus der anlagenabhängigen □
DYNASYS Antriebsberechnung. □
Traction sheave diameter, sheave width and form of grooves will be calculated in accordance to the □
applied lift values.

Werkstoff		Rohteil Zeichn.-Nr.:		Sachnummer		Format DIN A 3	
Allgemeintoleranzen ISO 2768-m		Rohteil Sachnummer:					
Diese technische Unterlage hat gesetzlichen Schutz (DIN34).		Erstellt		Geändert		Maßstab 1: 5	
Plotdatum		Datum		Datum		Sprache	
Plotsteller		Name		Name		de	
für Abteilung		24.8.04		Skupin		Blatt 1/1	
Plotstatus		24.8.04		Daniel		Zusatz	
Änd.- Index		Änderungs-Bemerkung		Zeichnung-Nr.		8S008DM010-8	
Teileklasse		FLENDER		Motor SVM 250-08-10			
Ers. für		LOHER		-ROBA stop silenzio 800			
Ursprung		Systemtechnik					

Option - Seilsprungsicherung
on request only - rope guard

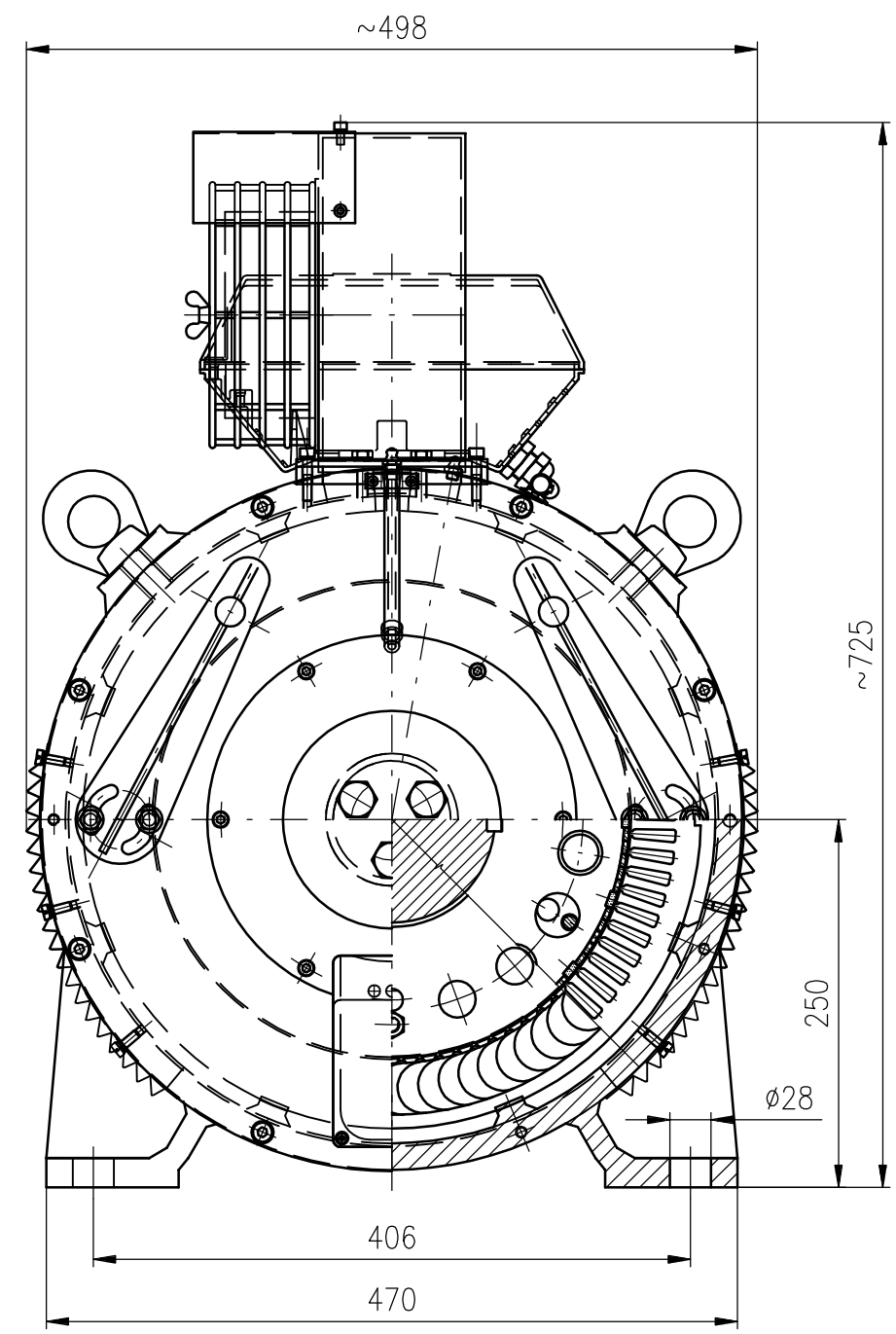
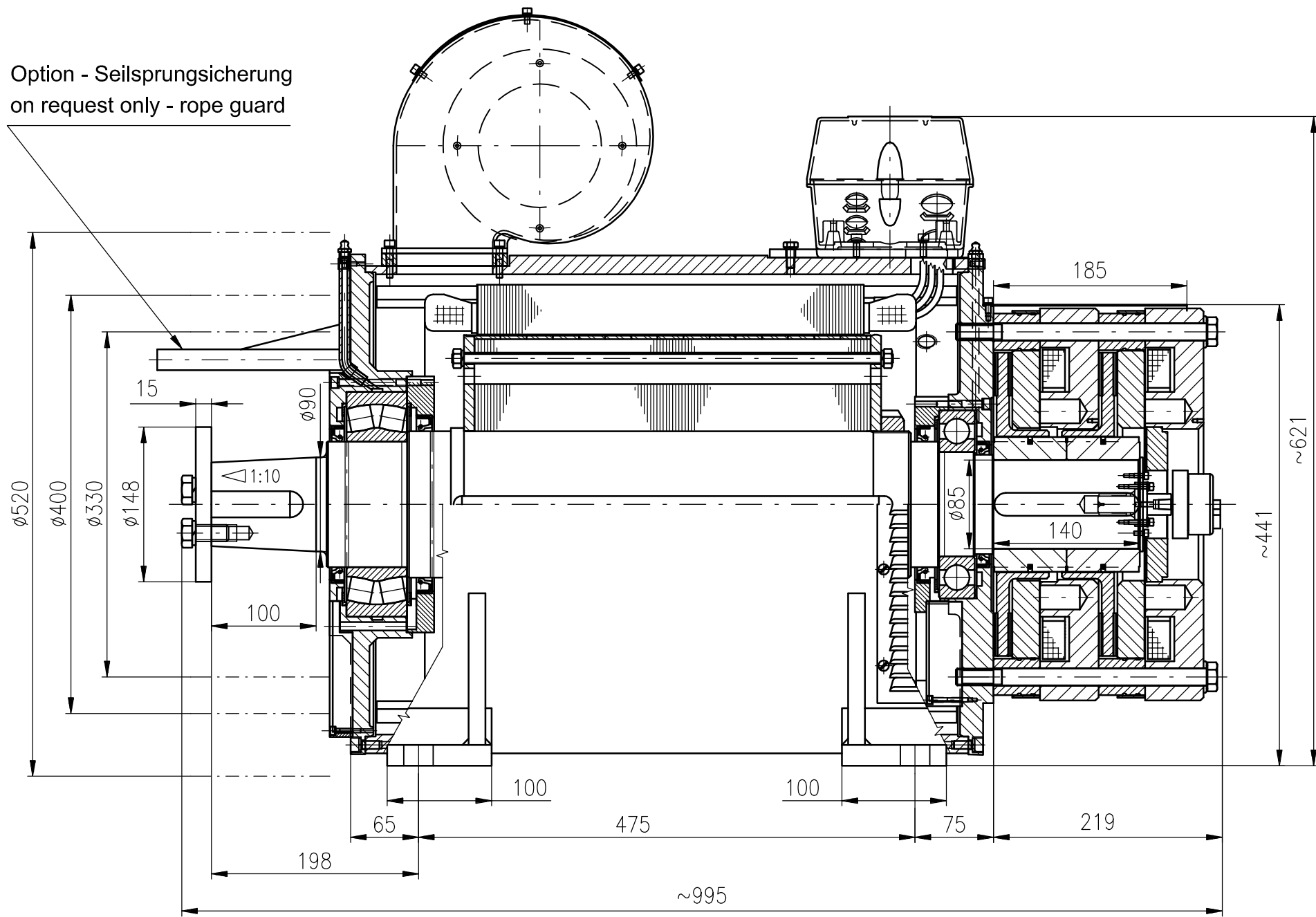

Treibscheibendurchmesser, - Kranzbreite und Rillenform - siehe DYNASYS®-S Antriebsberechnung
sheave-diameter, -width and form of grooves - see DYNASYS®-S drive calculation

Werkstoff		Rohteil Zeichnung-Nr.:		Sachnummer		Format DIN A 3	
		Rohteil Sachnummer:					
Allgemeintoleranzen ISO 2768-m				Erstellt		Geändert	
Diese technische Unterlage hat gesetzlichen Schutz (DIN34).				Datum		Name	
Plotdatum		Plotersteller		für Abteilung		Maßstab 1: 5	
Plotstatus				Bearb.		Sprache	
				12.5.05		de	
				Gepr.		Blatt	
				12.5.05		1/1	
				Zeichnung-Nr.		Zusatz	
				8S013DM070-1			
And-Index		Änderungs-Bemerkung		Teileklasse		Motor SVM 250-13-15	
				Ers. für		-ROBA stop silenzio 1300	
				Ursprung			
				FLENDER LOHER Systemtechnik			

Servicestationen/ servicecenters

Deutschland/ Germany

Elektromotor & Technik GmbH
Vertrieb und Service
Friedrichstraße 14
09380 Thalheim/Erzgebirge
Tel.-Nr. 03721-84313
Fax Nr. 03721-84256
e-mail elektromotorthalheim@t-online.de

EAB Elektro Anlagenbau GmbH
Flethstraße 29
21683 Stade-Buetzflath
Tel.-Nr. 04146-9088-0
Fax Nr. 04146-9088-50
e-mail eab@eab-stade.de

Naumann Alfred
Elektr. Masch. Bau
Inh. Friedrich Martin
Hertzstraße 5
30827 Garbsen
Tel.-Nr. 05131-1548
Fax Nr. 05131-95025
e-mail t.heeren@alfrednaumann.de

Vogelsang & Benning GmbH
Hansastr. 92
44866 Bochum-Wattenscheid
Tel.-Nr. 02327-547-0
Fax Nr. 02327-547-100
e-mail info@vogelsangbenning.de

Hiller Antriebssysteme GmbH
In der Vorstadt 19/1
72768 Reutlingen
Tel.-Nr. 07121-5807-08
Fax Nr. 07121-5807-38
e-mail service@hiller-Antriebssysteme.de

Scheba
Hafenstraße 36
97424 Schweinfurt
Tel.-Nr. 09721-69079
Fax Nr. 09721-609506
e-mail engelbrecht@scheba.de

Hansa-Motoren Reparaturbetr. GmbH & Co.KG
Dannenkamp 26-28
22869 Schenefeld / Hamburg
Tel.-Nr. 040-853-771-0
Fax-Nr. 040-853-771-33
e-mail info@hansa-motoren.de

Siebert Elektromaschinenbau GmbH
Bunsenstraße 5-7
64295 Darmstadt
Tel. 06151-824462
Fax-Nr. 06151-895590
e-mail info@siebertgmbh.de

Ausland/ international

NIEDERLANDE
LOHER Benelux
NL-3771 ME Barneveld
Tel.-Nr. 0031-342-404660
Fax Nr. 0031-342-404661
e-mail t.brink@loher.nl

ISRAEL
Amin Engineers Ltd.
POB 1676
IL-Ramat Hasharon 47-113
Tel.-Nr. 00972-3-5408577
Fax Nr. 00972-3-5493974
e-mail rosmeir@amin.co.il

UNGARN
Elmot Kft.
Pf. 7
1276 Budapest
Tel.-Nr. 0036-26-389 035
Fax Nr. 0036-26-389 943
e-mail elmot@mail.matav.hu

GROSSBRITANNIEN
ILE Manufacturing Limited
Service Department
Wanlip Road
Syston, Leicester UK-LE7 1PD
Tel.-Nr. 0044/116-2690900
Fax Nr. 0044/116-2690939
Mobil 0044-7971951222
e-mail r.taylor@ilem.co.uk

SPANIEN
SICAL Automation S.L.
C/Motilla del Palancar, 13
28043 Madrid
Tel.-Nr. 0034-91-300 55 15
Fax Nr. 0034-91-300 57 81
e-mail alvarob-sical@ctv.es

CHINA
LM LIFTMATERIAL
(Hong Kong) LTD.
Rm. 1403, Winning Centre 29
Tai Yau St., San Po Kong
Kowloon, Hong Kong, Imhkg
Tel. Nr. 00852-2194 1766
Mobil: 00852-9735 6781
Fax Nr. 00852 2194 7322
e-mail lmhkg@hkstar.com

Shanxi Explosion-Proof Motor (Group) CO.,Ltd.
Cheng Bei Street
13903451122
046011 Shanxi China
Tel.-Nr. 0086-355-2078620
Handy 0086-13903451122
Fax Nr. 0086-355-2078666
e-mail gfw3451122@sohu.com

LOHER GmbH

Postfach 1164
94095 Ruhstorf
Hans-Loher-Straße 32
94099 Ruhstorf

Servicezentrale/
servicecenter

24 h hotline:
Internet:

Tel.-Nr. 08531-39-554
Fax Nr. 08531-39-569
e-mail service.sys@loher.de
Tel.-Nr. 08531-39-222
<http://www.loher.de>